

BILL OF MATERIALS		
PART #	PART NAME	QUANTITY
1	CHASSIS	1
2	STEERING WHEEL	1
3	SHIFTER	1
4	WARNING SIGN	1
5	WHEEL WELL	4
6	AXLE	2
7	AXLE END	2
8	SPACER	4
9	LEFT WHEEL	2
10	RIGHT WHEEL	2

NOTE: ALL CONNECTIONS ARE SNAP-FIT EXCEPT AS NOTED

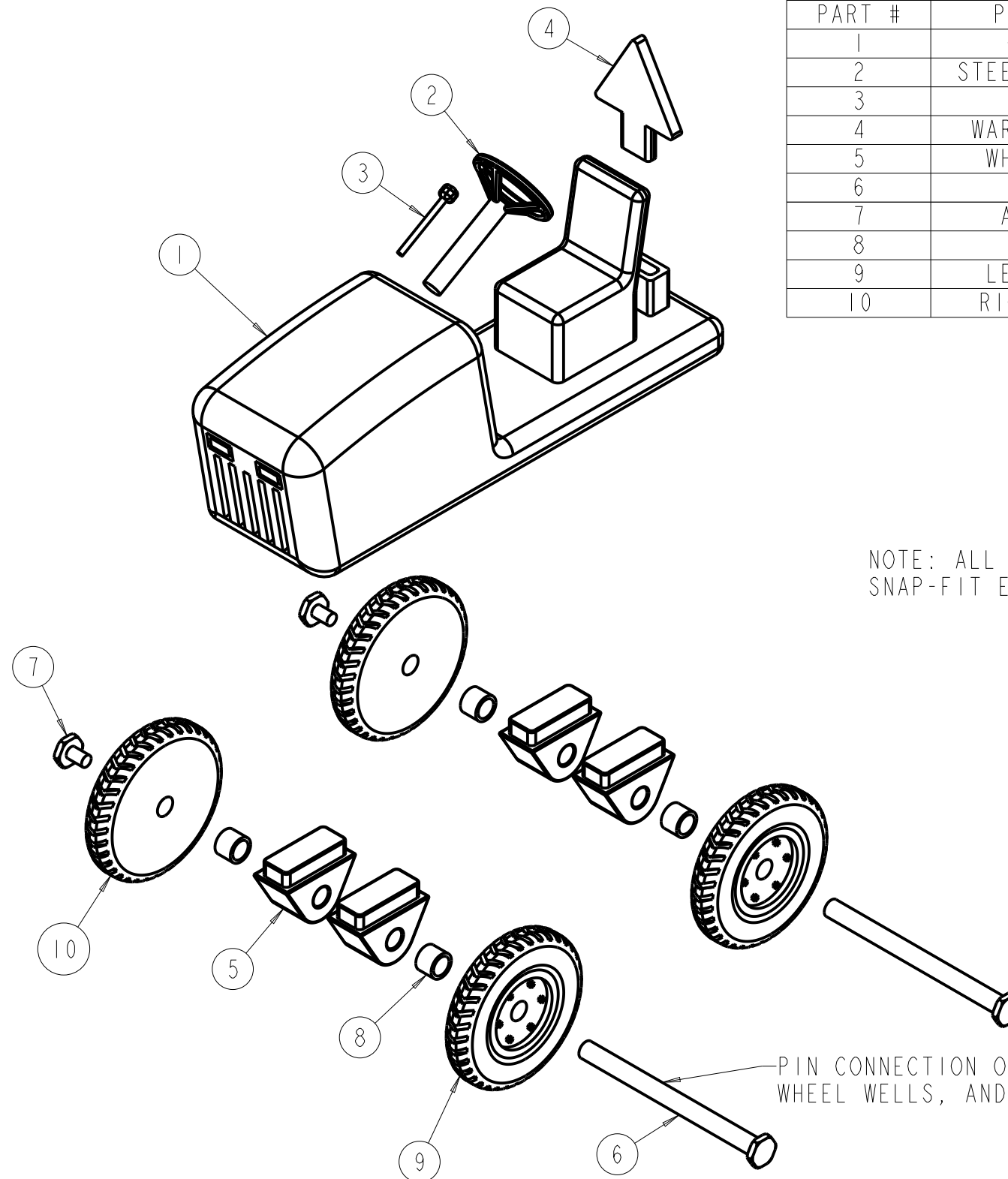

PIN CONNECTION OF AXLE TO WHEELS, WHEEL WELLS, AND SPACER

DIMENSIONAL TOLERANCE	
.x	= ± .1
.xx	= ± .05
.xxx	= ± .005
ANGLES	= ± 1°

BRIGHTON HIGH SCHOOL
BRIGHTON, MI

DWG: TOY TRACTOR

DWG BY: JOSEPH ZAWISA

HR: 3

DATE: 12/9/16

SCALE: NONE

SH: 1 OF 1